

NOTE:

- 1. SUPPORT PIPING SO THAT THERE IS NO WEIGHT ON PUMP.
- 2. PROVIDE INERTIA BASE WHEN REQUIRED BY SPECIFICATION, OTHER DETAILS OR SCHEDULES.

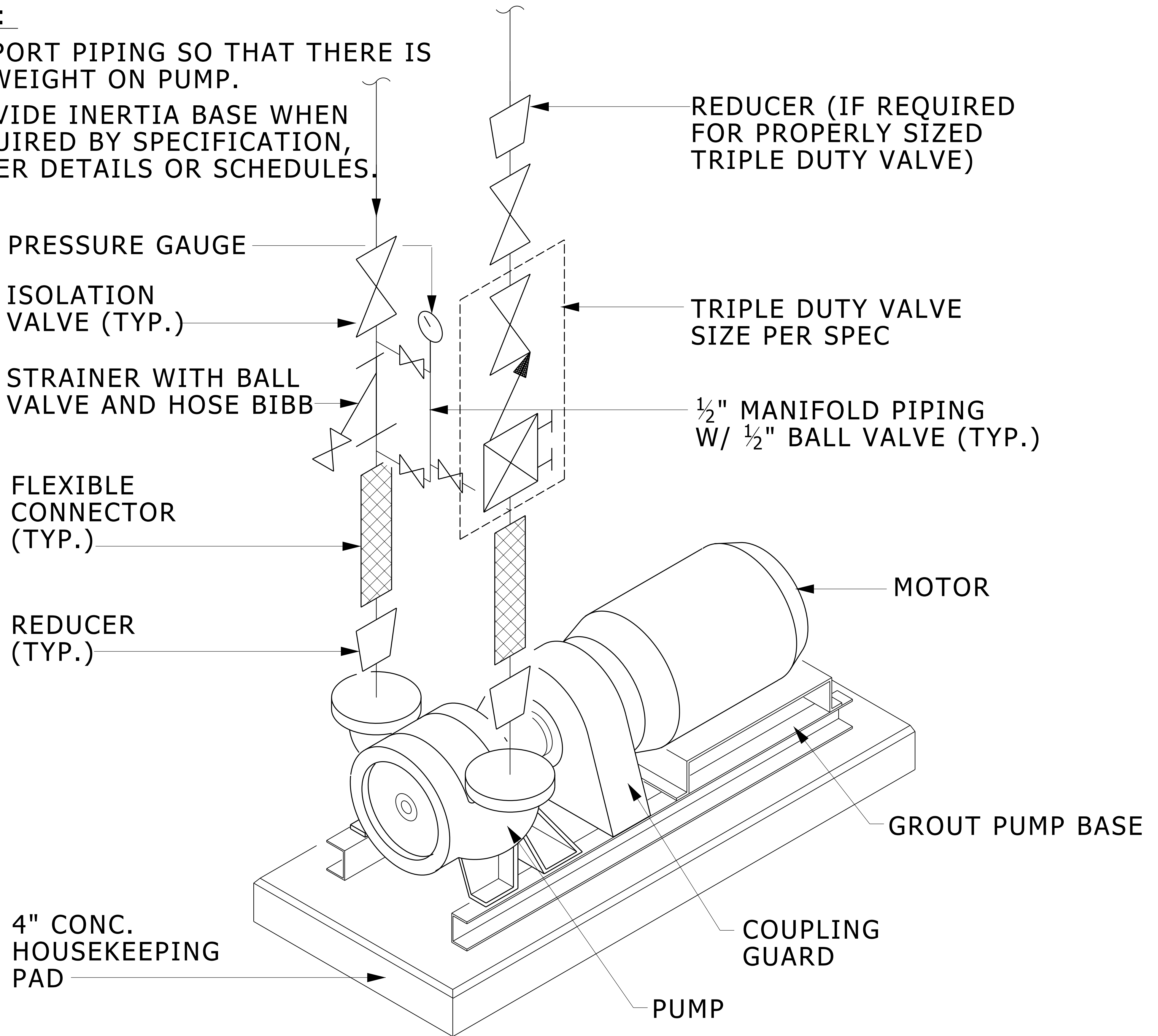

VERTICAL SPLIT CASE PUMP INSTALLATION DETAIL

NO SCALE

MD 232123 003 2012-11-01

DESIGNER NOTE: FOR VARIABLE VOLUME SYSTEMS,
DELETE TRIPLE DUTY VALVE AND SHOW A CHECK
VALVE INSTEAD.